

Tutorial Lessons in Maths



Speed-Time Graphs

TiM



by Kenneth Morley

© 2005 All rights reserved

Best viewed at 100%



Table Of Contents

* Introduction [page 3](#)

Lesson 01

*Speed - time examples..... [page 4 - 8](#)

* Speed - time tutorial [page 9 - 11](#)

* Speed - time solutions [page 12 - 13](#)

Introduction



Kenneth Morley has been a Mathematics Teacher for over 25 years. He has taught the age range 11 - 19. He graduated with an Upper Second Bachelor of Science Honours degree in Mathematical Sciences (subjects included pure/ applied mathematics, statistics, numerical analysis and computing). He acquired a Post Graduate Certificate in Mathematical Education

shortly afterwards. Both qualifications were gained in the United Kingdom.

A Message from the Tutor

Thank for you downloading and viewing this sample tutorial lesson. The lesson comprises of three examples, six questions and comprehensive solutions.

This tutorial lesson is intended for two types of users:

- 1 mathematics teachers who require topic exercises
- 2 anyone who wants to improve their mathematical skills & understanding.

For group 1, exercises can be set in class or given out as homework, and followed up with a solution sheet. It is ideal for exam revision when time is limited.

For group 2, exercises can be completed at your own pace, and the solution sheets can be referred to when you get stuck or to assess your answers.

One of my principal aims is to create quality products. A great deal of time went into viewing the suitability of questions, relating examples to questions and sequencing questions in order of difficulty. I gave a great deal of attention to the solutions, making them as comprehensive as possible so that they can easily be followed.

All the lessons have been tested in the classroom and have worked well. I have found with standard textbook exercises, many of the questions are different from the given examples, and there is at least one question (often in the near the beginning) which is quite difficult.

Please feel free to use this lesson, either in the classroom or as a tutorial, and pass it on to your friends. However, please respect copyright as this tutorial lesson is not for resale

Copyright Notice

This sample e-tutorial lesson is the exclusive property of the author or his licensors and is protected by copyright and other intellectual property laws.

The download of this sample e-tutorial lesson is intended for the User's personal and non - commercial use. Any other use of this sample tutorial lesson is strictly prohibited.

Users may not modify, transmit, publish, participate in the transfer or sale of, reproduce, create derivative works from, distribute, perform, display, or in any way exploit, any of the content of this activity, in whole or in part.

You can print out for classroom use, or as a tutorial booklet to work through at home.

Tutorials are arranged in two packages - 6 Pack and 12 Pack.

For each 6 Pack there are 5 mathematics tutorials, and a review tutorial.

For each 12 Pack there are 10 mathematics tutorials and 2 review tutorials.

To buy a package please visit <http://www.tutorialsinmaths.com>

Lesson 01

Speed - time Graphs

Theory

For the purpose of this lesson or tutorial we are only considering linear (or uniform) rates of change.

A typical speed - time graph will describe a uniform acceleration of a body from rest, until a certain speed is attained. That speed is maintained for a certain period of time, and then the body undergoes uniform deceleration and slows down until it stops.

A speed - time graph will look like this:

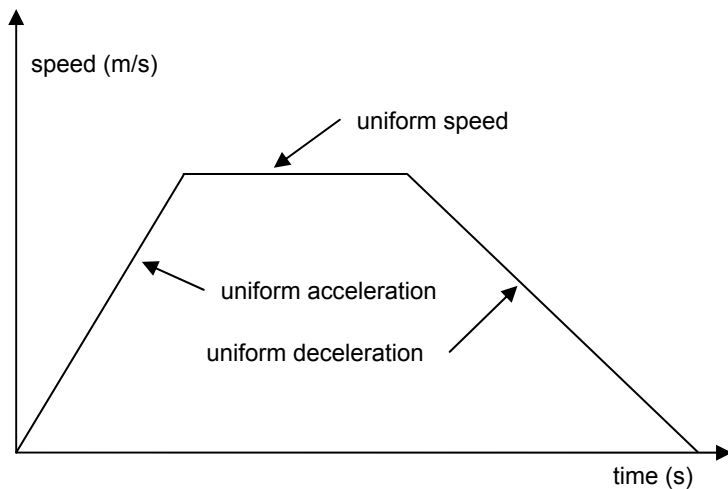

Both acceleration and deceleration are describe by positive and negative gradients of lines. Uniform speed is described by a line which is parallel to the time axis.

S I Units

acceleration (+a) = gradient of line

$$a = \frac{\frac{m}{s}}{s} = \frac{m}{s^2} = m/s^2$$

The unit of measurement for acceleration is m/s^2

Deceleration (-a) is measured in $-m/s^2$

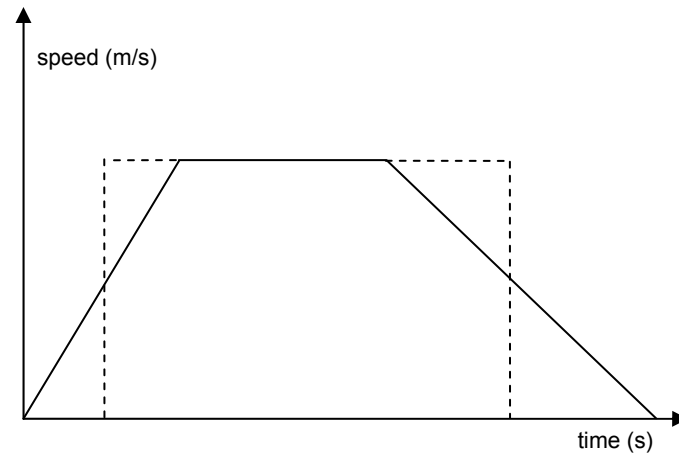

Distance (s) = area under the graph

$s = \text{height} \times \text{base}$

$$s = \frac{m}{s} \times s = m$$

distance (s) is measured in metres (m)

Equation of motion

If u is the initial velocity and v is the final velocity of a body then acceleration is the change in velocity with respect to time.

$$a = \frac{v - u}{t}$$

$$at = v - u$$

$$\text{or } v = u + at$$

Examples

1

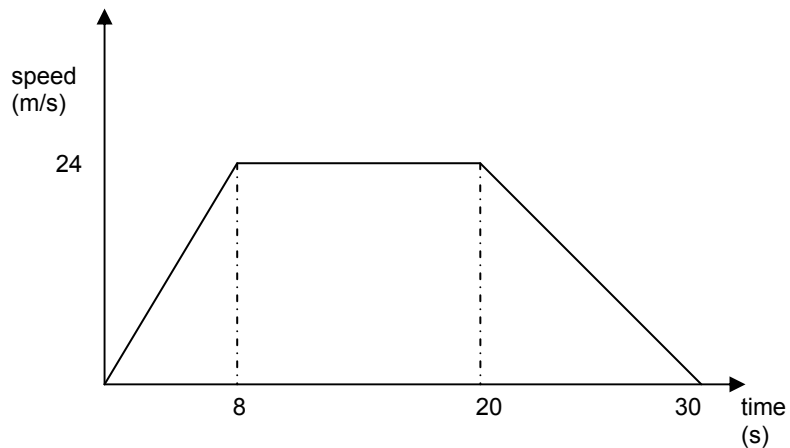

The diagram above shows a speed - time graph of a car

- Calculate the acceleration of the car during the first 8 seconds
- Calculate the deceleration of the car during the last 10 seconds
- Calculate the total distance travelled.

Solution

a Acceleration

$$a = \frac{24}{8} = 3\text{m/s}^2$$

b Deceleration

$$a = \frac{-24}{(30 - 20)} = -\frac{24}{10} = -2.4\text{m/s}^2$$

c Distance travelled = area of the trapezium

$$= \frac{1}{2}(30 + [20 - 8]) \times 24$$

$$= \frac{1}{2}(30 + 12) \times 24$$

$$= \frac{1}{2} \times 42 \times 24$$

$$= 504 \text{ m}$$

2

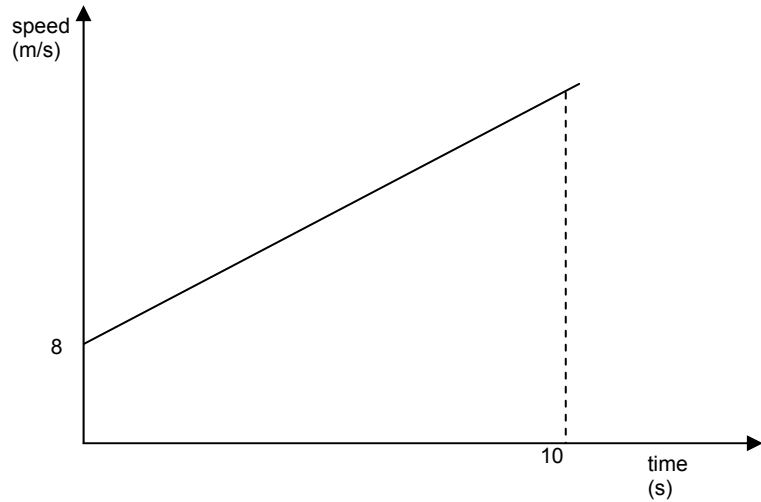

The diagram above shows a speed - time graph of a car which accelerates at 2 m/s^2 for 10 seconds. Its initial speed is 8 m/s

- a Calculate the speed of the car after 4 seconds
- b Calculate the total distance travelled
- c Write down a formula for the speed v in terms of time t

Solution

- a $\text{speed} = 8 + (2 \times 4) = 16 \text{ m/s}$
- b $\text{speed after 10 seconds} = 8 + (2 \times 10) = 28$
 $\text{distance travelled} = \frac{1}{2}(8 + 28) \times 10 = 180 \text{ m}$
- c $v = 8 + 2t$

3

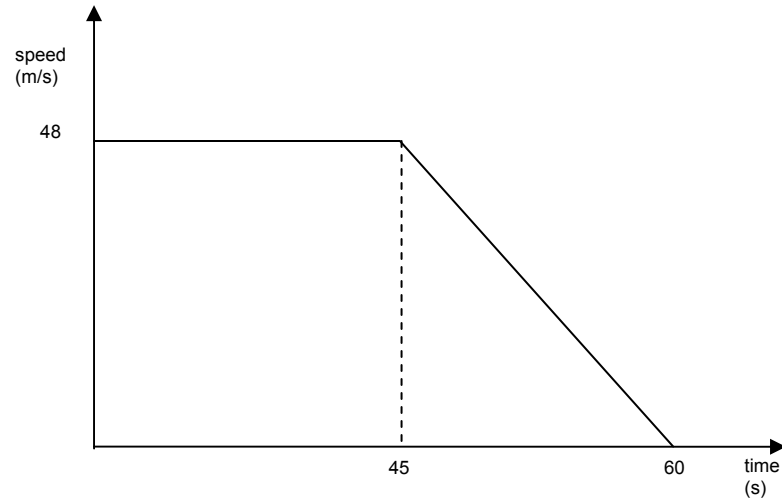

The diagram above shows a speed - time graph of a fast racing car. It travels at a constant speed of 48 m/s for 45 seconds and then slows down uniformly before coming to rest in another 15 seconds

- a Calculate the speed of the car after 50 seconds
- b Calculate the average speed of the car during the 60 seconds

Solution

a Using similar \triangle s

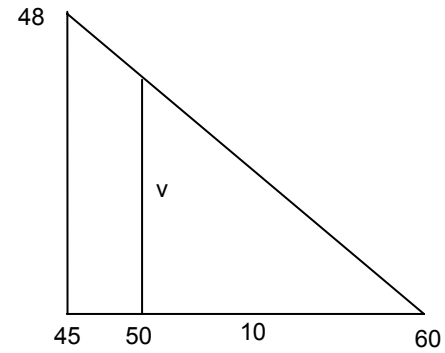

$$\frac{v}{10} = \frac{48}{(60 - 45)}$$

$$\frac{v}{10} = \frac{48}{15}$$

$$v = \frac{48}{15} \times 10 = 32 \text{ m/s}$$

Q3 Alternative Solution (part a)

speed = acceleration x time

$$v = at$$

$$a = \frac{48}{(60 - 45)} = 3.2$$

$$t = 60 - 50 = 10$$

$$v = 3.2 \times 10 = 32 \text{ m/s}$$

b total distance travelled

$$= \frac{1}{2}(45 + 60) \times 10 = 2,520 \text{ m}$$

Average speed = $\frac{\text{total distance}}{\text{total time}}$

$$= \frac{2520}{60} = 42 \text{ m/s}$$

Lesson 01 Tutorial

1

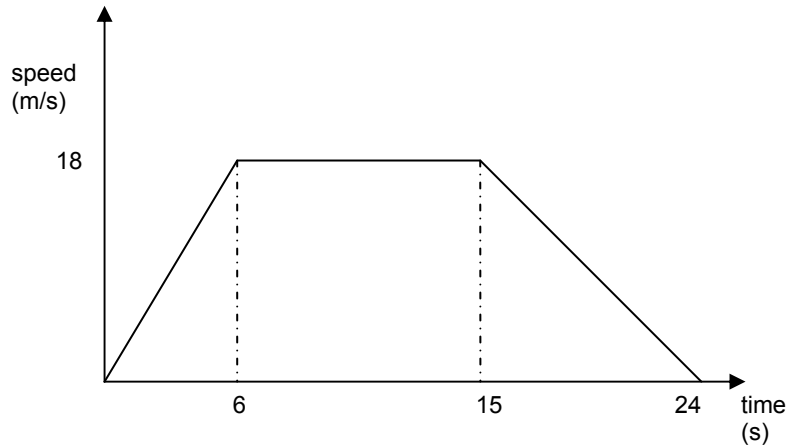

The diagram above shows a speed - time graph of a car.

- Calculate the acceleration of the car during the first 6 seconds
- Calculate the deceleration of the car during the last 9 seconds
- Calculate the total distance travelled.

2

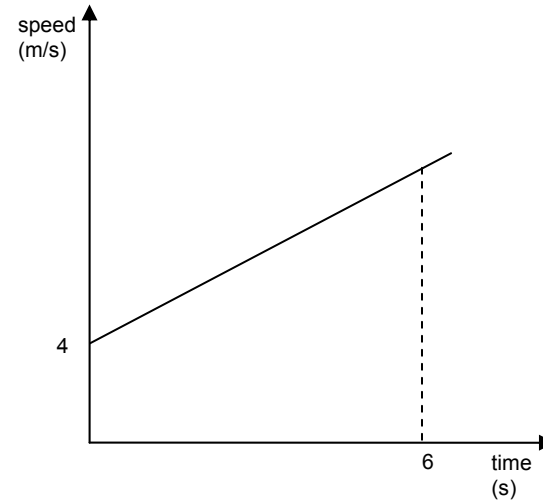

The diagram above shows a speed - time graph of a car which accelerates at 3 m/s^2 for 6 seconds. Its initial speed is 4 m/s .

- Calculate the speed of the car after 4 seconds
- Calculate the total distance travelled
- Write down a formula for the speed v in terms of time t .

3

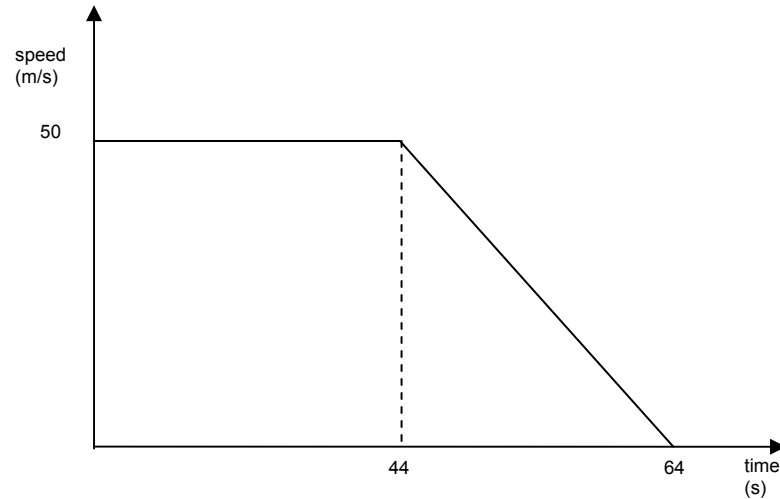

The diagram above shows a speed - time graph of a fast racing car. It travels at a constant speed of 50 m/s for 44 seconds and then slows down uniformly before coming to rest in another 20 seconds.

- a Calculate the speed of the car after 48 seconds
- b Calculate the average speed of the car during the 64 seconds.

4

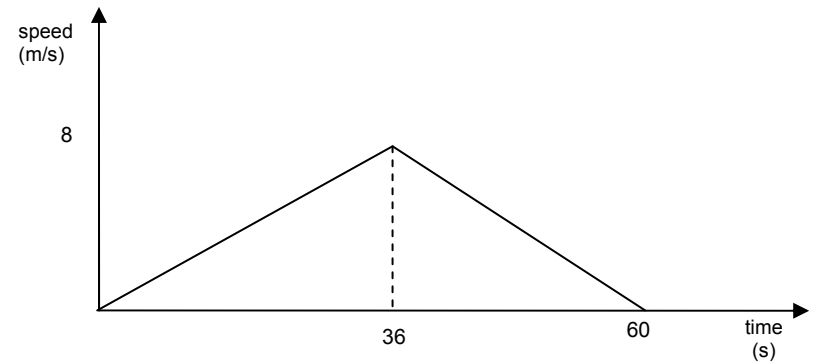

A car starts from rest and accelerates uniformly until it reaches a speed of 8 m/s. It then slows down uniformly until coming to rest after traveling for 60 seconds.

- a Calculate the acceleration of the car during the first 36 seconds
- b Calculate the total distance travelled during the 60 seconds
- c Change the speed of 8 m/s into km/h.

5

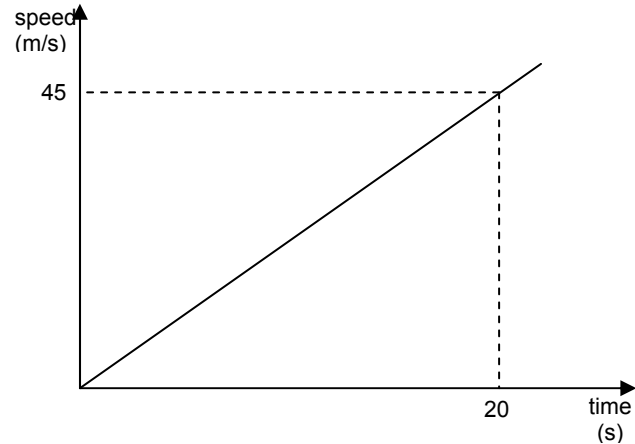

A motorbike starts from rest and accelerates uniformly until it reaches a speed of 45 m/s after 20 seconds.

- Calculate the acceleration of the motorbike
- Calculate the speed of the motorbike after 16 seconds
- Calculate the average speed of the motorbike in km/h after it has travelled 20 seconds.

6

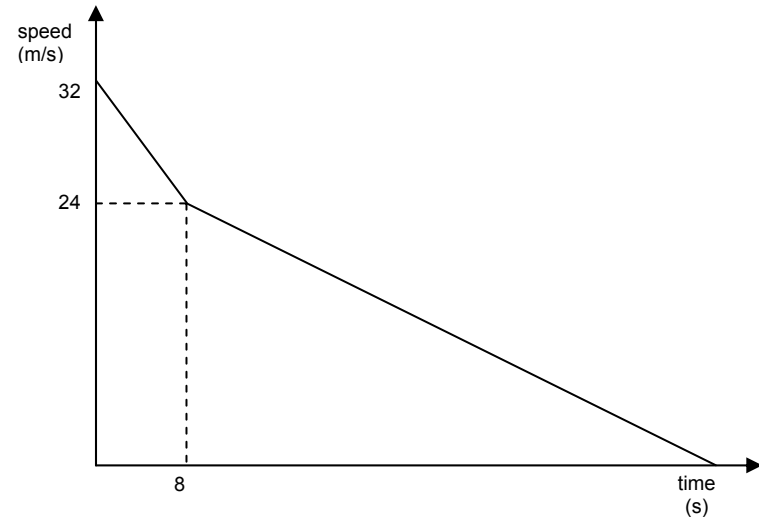

A truck brakes uniformly from 32 m/s to 24 m/s in 8 seconds. It then further brakes at 0.5 m/s^2 until it comes to rest.

- Calculate the deceleration of the truck in the first 8 seconds
- Calculate the total time that the truck takes to come to rest
- Calculate the total distance travelled by the truck.

Lesson 01 Solutions

Notation used:

- ❖ +a = acceleration,
- ❖ -a = deceleration
- ❖ v = final speed (or just speed)
- ❖ v_a = average speed
- ❖ $v_{\text{km/h}}$ = speed in km/h
- ❖ u = initial speed
- ❖ s = distance
- ❖ t = time

Equation of Motion

- ❖ $v = u + at$

Solutions

- 1a acceleration of the car during the first 6 seconds

$$a = \frac{18}{6} = 3\text{m/s}^2$$

- b deceleration of the car during the last 9 seconds

$$a = -\frac{18}{9} = -2\text{m/s}^2$$

- c total distance travelled

$$s = \frac{1}{2}(24 + 9) \times 18 = 297\text{m}$$

- 2a speed of the car after 4 seconds

$$v_4 = 4 + (3 \times 4) = 16 \text{ m/s}$$

- b total distance travelled

1st calculate the speed after 6 seconds:

$$v_6 = 4 + (3 \times 6) = 22 \text{ m/s}$$

then calculate the distance travelled

$$s = \frac{1}{2}(4 + 22) \times 6 = 78\text{m}$$

- c formula for the speed v in terms of time t

$$v = u + 3t$$

- 3a speed of the car after 48 seconds

1st calculate the deceleration

$$a = -\frac{50}{20} = -2.5\text{m/s}^2$$

then use the formula $v = u + at$ where $u = 50 \text{ m/s}$, $a = -2.5 \text{ m/s}^2$ and $t = 48 - 44 = 4\text{s}$

$$v = 50 - (2.5 \times 4) = 50 - 10$$

$$v = 40 \text{ m/s}$$

- b average speed of the car during the 64 seconds

1st calculate the distance travelled

$$s = \frac{1}{2}(44 + 64) \times 50 = 2700$$

then calculate the average speed

$$v_a = \frac{2700}{64} = 42.2\text{m/s}^2$$

4a acceleration of the car during the first 36 seconds

$$a = \frac{36}{8} = 4.5 \text{ m/s}^2$$

b total distance travelled during the 60 seconds

$$s = \frac{1}{2} (60 \times 8) = 240 \text{ m}$$

c speed of 8 m/s in km/h

$$v_{\text{km/h}} = \frac{8 \times 60 \times 60}{1000} = 28.8 \text{ km/h}$$

5a acceleration of the motorbike

$$a = \frac{45}{20} = 2.25 \text{ m/s}^2$$

b speed of the motorbike after 16 seconds

1st use $v = u + at$, where $u = 0$ and $a = 2.25 \text{ m/s}^2$

$$v = 2.25 \times t$$

$$v = 2.25 \times 16$$

$$v = 36 \text{ m/s}$$

c average speed of the motorbike in km/h after it has travelled 20 seconds

1st calculate distance travelled:

$$s = \frac{1}{2} (20 \times 45) = 450 \text{ m}$$

then calculate average speed in m/s

$$v_a = \frac{450}{20} = 22.5 \text{ m/s}$$

finally calculate average speed in km/h

$$v_{\text{km/h}} = \frac{2.25 \times 60 \times 60}{1000} = 81 \text{ km/h}$$

6a deceleration of the truck in the first 8 seconds

$$a = -\frac{(32 - 24)}{8} = -1 \text{ m/s}^2$$

b total time that the truck takes to come to rest

1st calculate time taken to slow from 24m/s to rest

use $v = u + at$, where $u = 24 \text{ m/s}$ and $a = -0.5 \text{ m/s}^2$

$$v = 24 - 0.5 \times t$$

when the truck comes to rest its final speed is 0 m/s so

$$0 = 24 - 0.5t$$

hence

$$t = \frac{24}{0.5} = 48 \text{ s}$$

total time = time taken for slowing down from 32 m/s to 24 m/s and

then from 24 m/s to 0 m/s

$$\text{total time} = 8 + 48 = 56 \text{ s}$$

c total distance travelled by the truck

this is the area of the small \triangle plus area of the rectangle plus area of the large \triangle

$$s = \frac{1}{2} (8 \times 8) + (24 \times 8) + \frac{1}{2} (24 \times 48)$$

$$s = 32 + 192 + 576$$

$$s = 800 \text{ m}$$